

## ZG 631 Manhole—7' x 7' (84" x 84")

### 1. Scope

This specification outlines the minimum requirements for 7' x 7' manholes to be used in full-traffic or incidental traffic areas. The specification applies regardless of whether the manhole is installed by the customer, contractor, supplier or company personnel.

### 2. Applicable Documents

The latest revisions of the documents, standards, codes and requirements listed in 2.1, Company Material Specifications, and 2.2, Codes and Standards, in effect on the date of invitation to bid apply to the extent specified herein.

#### 2.1. Company Material Specifications

ZG 301, General Equipment Base and Enclosure Requirements

ZG 311, Concrete Requirements

ZG 811, Full-Traffic Cover and Frame Assembly

#### 2.2. Codes and Standards

AASHTO H-20 (for manholes beneath roadways)

ASTM C857 A-8 (for manholes beneath incidental light truck traffic)

### 3. General

This specification states material and construction requirements which are applicable only to 7' x 7' manholes.

### 4. Design and Manufacturing Requirements

The purpose of a 7' x 7' manhole is to provide an enclosure for cable pulling, splicing, and single-phase switching.

#### 4.1. Manhole Layout

Figure 1 and Figure 2 show the assembled 7' x 7' manhole with dimensions. The manhole is made up of an enclosure, and a cover and frame assembly. Unless otherwise approved by company engineering, all dimensions and placement of hardware shall conform to those shown in Figure 1, Figure 2, and Figure 3, shown below. See Figure 3 for enclosure layout. All manhole enclosures shall be constructed to AASHTO H-20 (full-traffic) standards, regardless of the cover and frame assembly used.

#### 4.2. Lifting Attachments

Enough lifting attachments shall be provided to ensure safe installation of all pieces at the site.

### 4.3. Pulling Attachments

Cable pulling attachments shall be installed in each corner of the enclosure such that blocks may be attached for a straight cable pull. Pulling attachments shall have a minimum pullout strength of 6,000 pounds. Attachments shall allow the attachment of a clevis with a one-inch diameter through-bolt. Pulling attachments may be designed by the manufacturer to meet these requirements. See Figure 3 for location of pulling attachments.

### 4.4. Incidental Traffic Access Cover (SI# 7992594 only)

An incidental-traffic-rated access cover, as specified in ZG 811, shall be included with the assembly. The incidental-traffic-rated cover shall be no smaller than 36" x 60" and no larger than 48" x 60".

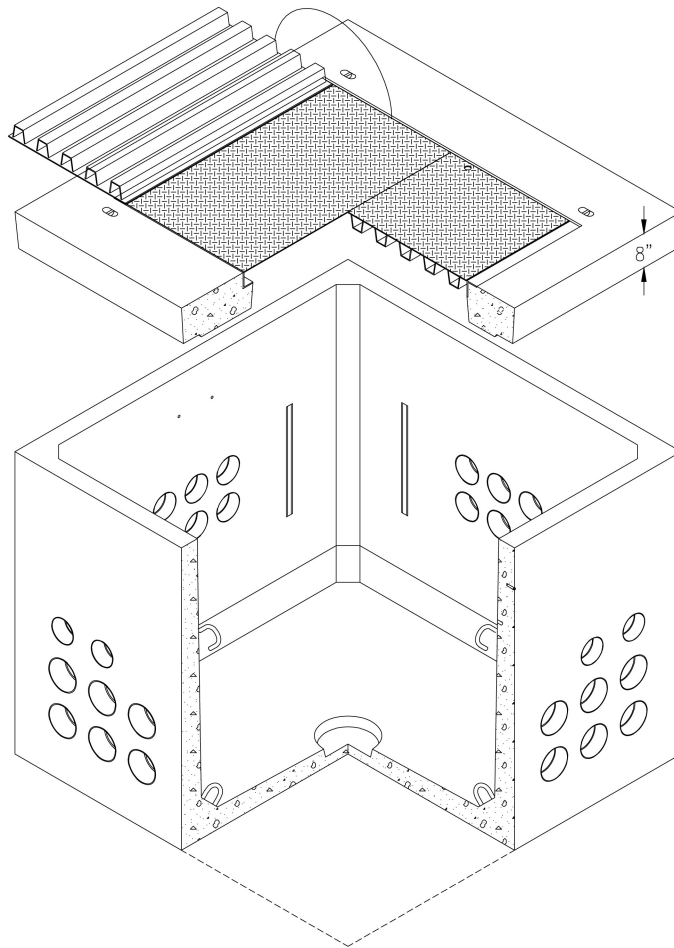

**Figure 1 — 7' x 7' Manhole with Incidental Traffic Cover (SI# 7992594)**

#### 4.5. Full Traffic Access Cover (SI# 7992595 only)

A full-traffic-rated access cover, as specified in ZG 811, shall be included with the assembly as shown in Figure 2 below. Additional rings may be used to bring to grade. (See ZG 811 for grade rings.)

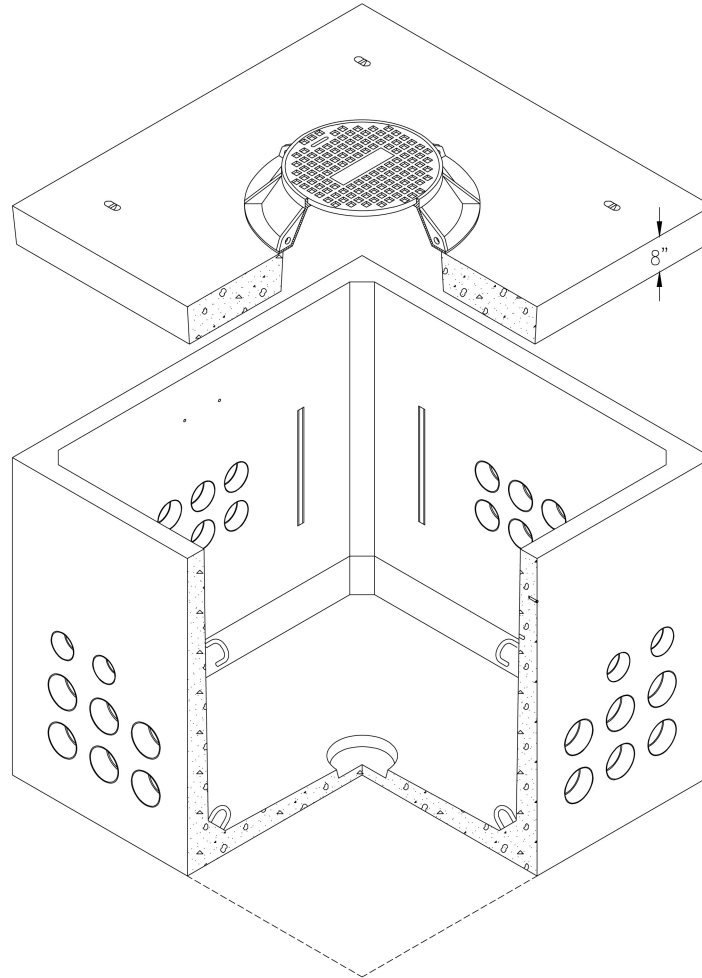

**Figure 2 — 7' x 7' Manhole with Full Traffic Cover (SI# 7992595)**

#### 4.6. Conduit Entrances

These units shall include Term-A-Duct or equivalent conduit entrances compatible with PVC, Polyethylene (PE), and Fiberglass 90°C-rated electrical-grade conduit. The Term-A-Duct entrances shall be positioned as follows:

- two adjacent walls (A&B walls): six 6.63" Term-A-Ducts as shown in Figure 3
- two adjacent walls (C&D walls): six 6.63" Term-A-Ducts, and two 4.5" Term-A-Ducts as shown in Figure 3

ZG 631 Manhole—7' x 7' (84" x 84")

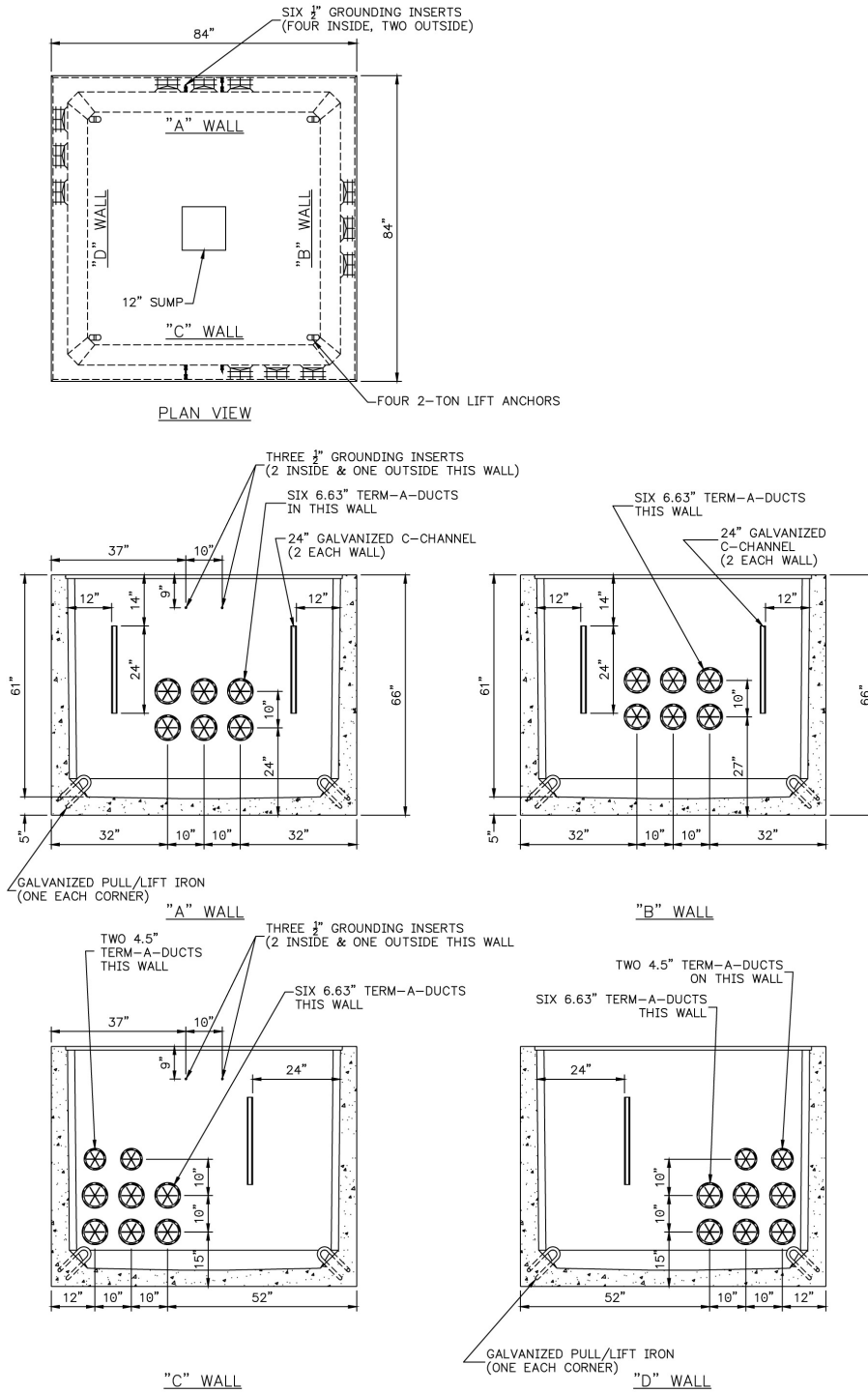

Figure 3 — 7' x 7' Manhole Enclosure Layout

### 4.7. Ground Grid

Each manhole shall be constructed with an encased electrode meeting NESC 094.B.6. The  $\frac{3}{8}$ " steel rebar shall be 20 continuous feet in length and imbedded in concrete at least 24" below finished grade (see Figure 4). The grounding system shall attach to a connection insert of high-strength bronze alloy, threaded to  $\frac{1}{2}$ " 13UNC. The vertical rebar attaching to the bronze insert shall be welded or connected by a minimum of a  $\frac{5}{8}$ " copper clad ground clamp to the  $\frac{3}{8}$ " steel rebar grounding loop. Two inserts, centered on opposite side walls, shall be available for connection on the inside and outside of the enclosure.

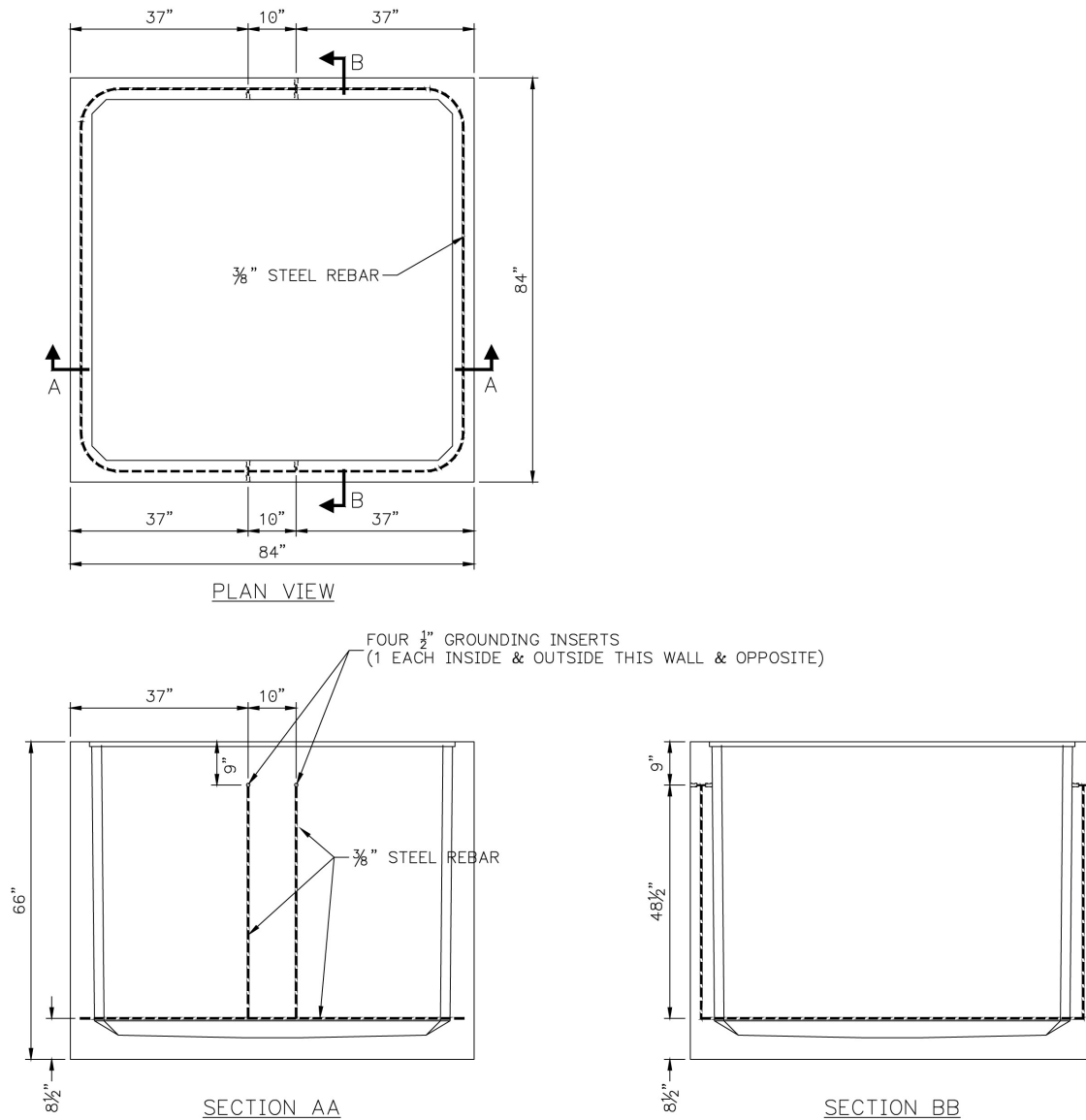

Figure 4 — 7' x 7 Manhole Ground Grid

**Material Specification**

Page 5 of 6  
 Published Date: 20 Dec 17  
 Last Reviewed: 20 Dec 17



#### 4.8. "C"-Channels

Each enclosure wall shall have two 2-foot-long galvanized or fiberglass  $1\frac{5}{8}$ " x  $\frac{13}{16}$ " "C"-channels. See Figure 3 for details.

#### 4.9. Installation

This unit shall be set at the site by the supplier. The contractor is responsible to ensure that all earth under the manhole is compacted to within 2% slope prior to setting the manhole. Where requested by the company, a clean 6-inch base of  $\frac{3}{4}$ "-minus gravel shall be provided under the enclosure, and must be compacted to 90% of dry density. The interface between the cover/frame assembly and the enclosure shall be sealed using a waterproof substance such as tar or mastic. The top of the pad shall be two to four inches above final grade in non-pedestrian areas, or flush with grade in pedestrian areas. Setting depth shall be determined by the local regulatory authority for full-traffic areas.

### 5. Testing & Compliance

Manholes submitted under this specification shall meet all tests and requirements contained in ZG 301, ZG 311, and this specification. Manholes shall also comply with requirements in applicable national standards.

### 6. Issuing Department

The engineering standards and technical services department of PacifiCorp published this material specification. This material specification shall be used and duplicated only in support of company projects.